

Spartan-3E PCI Development Kit

Colorado Electronic Product Design Rev 1.2 February 15, 2011

The PCI Development Kit is intended to aid in the development and test of algorithms and signal processing applications for PCI interfaces. A through-hole prototyping area is provided for user modifications. The PCI Development Kit offers the following:

- RS232 Level shifter interface
- Removable EEPROM for the PLX PCI IC
- 4 user definable push buttons
- 3 user definable LEDs
- Connector mounted FPGA platforms that allow for prototyping many different DSP and FPGA options
- Expansion connections (connectors are not included) providing 86 IO pins

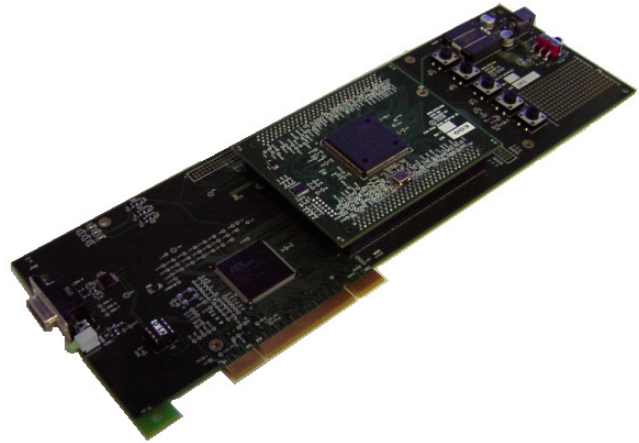

Description

The system combines a PCI card and a FPGA signal processing card. The PCI board acts as a mother board providing mounting connectors and a signal routing back plain for the FPGA board and other daughter boards. The kit will operate in standalone mode using a 12V power supply or the PCI card can be attached to a computer.

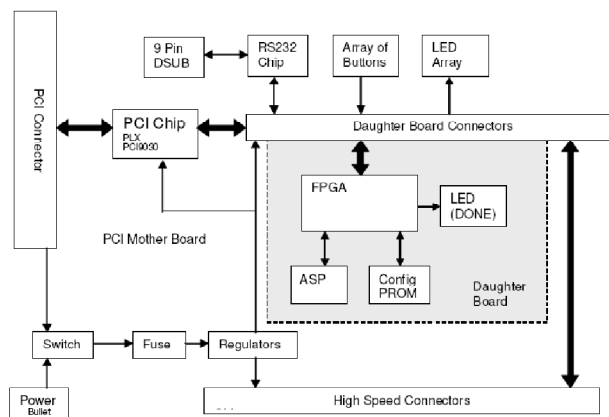

Figure 1 - Block Diagram of PCI Development Kit

Spartan-3E PCI Development Kit

Colorado Electronic Product Design Rev 1.2 February 15, 2011

The FPGA card contains a Xilinx Spartan[®] - 3E XC3S250E-4PQG208C, 250,000 gate FPGA. Users may customize the FPGA to implement their own algorithms. The FPGA card comes with a JTAG programming connector (14 pin) and a configuration PROM, Xilinx XCF02SVOG20C, to retain the FPGA settings. The PCI Development Kit allows the use of Xilinx's ISE program software to create custom algorithm code. The oscillator mounted on the FPGA card is a 133MHz surface mount oscillator.

The PCI card provides interfaces for the FPGA card to a computer PCI bus, RS232, user push buttons, and LED indicators. 2 computer PCI slots are required if the PCI Development Kit is used in a PC. The PCI interface utilizes a PLX PCI9030 chip to avoid using any resources in the PCI core, to maximize the space in the FPGA. The PLX is PCI v2.2 compliant and operates at a bus speed of 33MHz and has a data width of 32 bits. The PLX example code was not created to do bursting or DMA. A Windows[®] XP driver for the PCI chip and an example windows application is provided with the kit.

The PCI Development Kit provides expansion connectors (connectors are not placed) to allow for the addition of an analog card used for data acquisitions and Digital Radio designs. Schematics (Analog Board schematics are not included with the PCI Development Kit), and VHDL code are provided with the kit.

Specifications

Parameter	Minimum	Typical	Maximum	Units
Operating Temperature	0	25	70	°C
Input Voltage	9	12	15	VDC
Stand Alone Current Draw		100		mA
Oscillator		133		MHz ¹
PCI bus speed		33		MHz

¹ ±50ppm

Spartan-3E PCI Development Kit

Colorado Electronic Product Design Rev 1.2 February 15, 2011

Mechanical Specifications

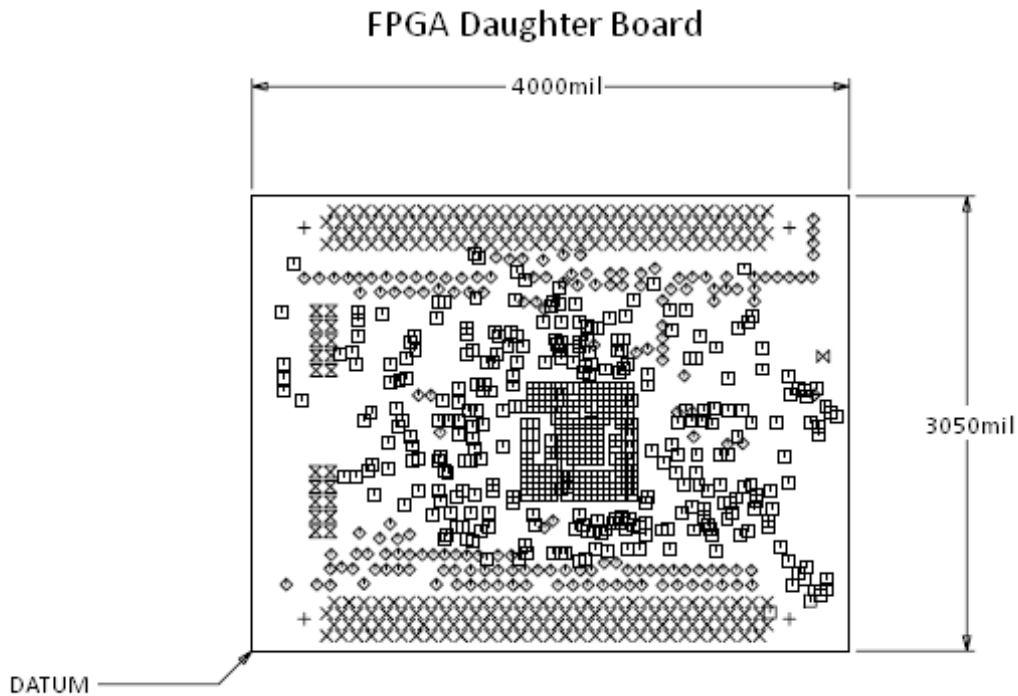
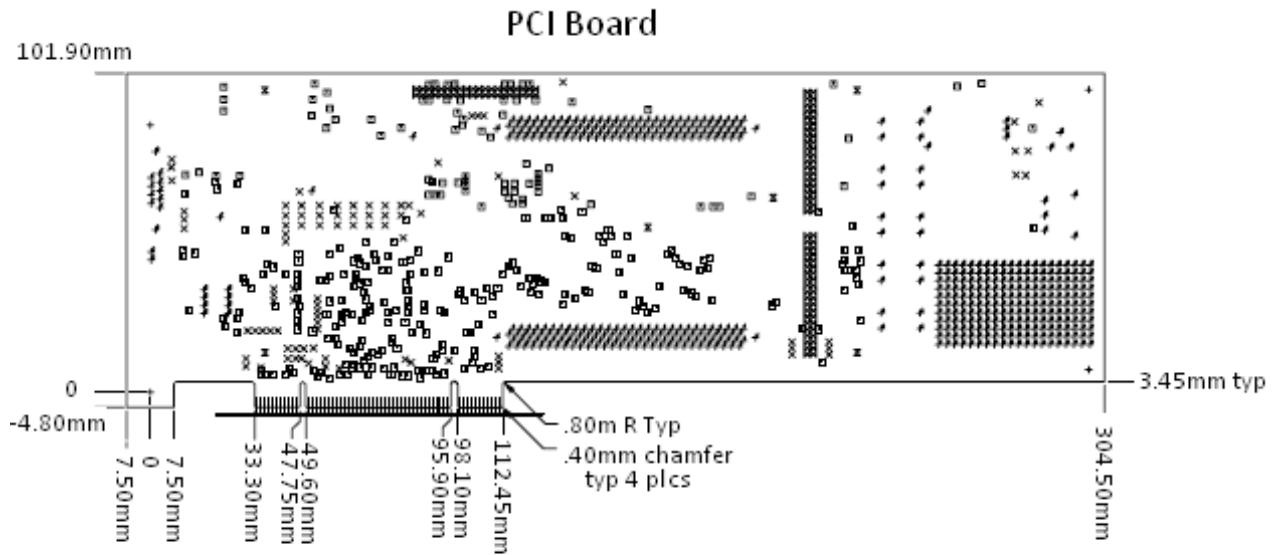

The PCI Development Kit ships with:

Colorado Electronic Product Design, Inc.
2995 Center Green, Suite A, Boulder Colorado 80301
Phone: (303) 415-1112 Fax: (720) 306-4445
<http://www.cepd.com>

Spartan-3E PCI Development Kit

Colorado Electronic Product Design Rev 1.2 February 15, 2011

- Bill of Materials
 - PCI Board Bill of Materials
 - Xilinx Spartan[®] 3E daughter board
- Data Sheets
 - Xilinx Spartan[®] 3E XC3S250E-4PQG208C
 - Xilinx EEPROM XCF02SVOG20C
- Windows[®] XP PCI Driver
- Schematics
 - PCI Board
 - Xilinx Spartan 3E[®] daughter board
- VHDL Examples
- User Manual
- 12 volt wall mount power supply